

MOVE 60 dynamic

As of: July 07, 2026

Description	Model	Carton Quantity
MOVE 60 dynamic 20W	D570	100 pcs per Carton

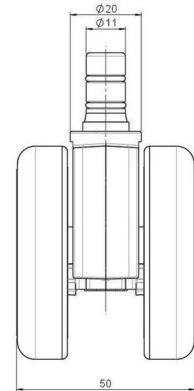
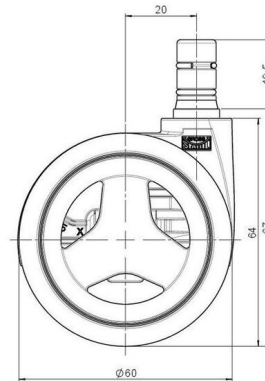

Technical Details

Product Type	Chair caster
Wheel diameter	60mm
Load capacity	50kg
Overall height with fixing	67mm
Wheel:	
Wheel type	Soft wheel
Wheel core / tread color	RAL 3001 Signal red / RAL 9005 Jet black
Housing:	
Housing form	unhooded, with neck diameter
Neck diameter	20mm
Housing material	High quality nylon
Housing color	RAL 9005 Jet black
Mobility concept	Unloaded braked, rc®-System
Fixing	No-Noise™ Stem, 11x19,5mm Push fit stem with double circlips, 11,4mm
Description	DUKG570 - 2X2NN

Fixings

Compatible with the following available fixings:

No-Noise™ Stem:

- 11x19,5mm with 11,4mm circlip
- 11x19,5mm with 110,6mm circlip

Push fit stems:

- 10x22mm with 10,3mm circlip
- 10x22mm with 10,5mm circlip
- 11x19,5mm with 11,4mm circlip
- 11x19,5mm with 11,8mm circlip
- 11x22mm with 11,4mm circlip
- 11x22mm with 11,6mm circlip
- 11x22mm with 11,8mm circlip

Threaded stems:

- M8x15mm
- M8x20mm
- M8x25mm
- M10x15mm
- M10x20mm
- M10x25mm
- M10x30mm
- M10x40mm
- M12x20mm

Square plates:

- 38x38mm
- 55x55mm
- 60x60mm