

Standard D068

As of: June 27, 2026

Description	Model	Carton Quantity
DUKF 68 -27 X10	D068	150 pcs per Carton

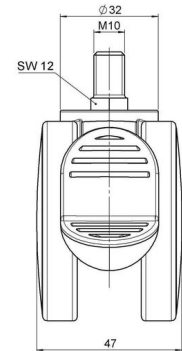
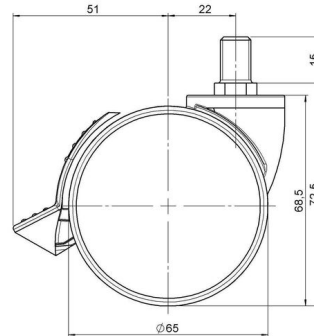

## Technical Details

Product Type	Furniture caster
Wheel diameter	65mm
Load capacity	65kg
Overall height with fixing	72,5mm
<b>Wheel:</b>	
Wheel type	Soft wheel
Wheel core / tread color	RAL 9006 White aluminium / RAL 9005 Jet black
<b>Housing:</b>	
Housing form	unhooded, with neck diameter
Neck diameter	32mm
Housing material	High quality nylon
Housing color	RAL 9006 White aluminium
Mobility concept	Stopper brake
Fixing	M10x15mm Threaded stem
Description	DUKF 68 -27 X10

## Fixings

Compatible with the following available fixings:

### No-Noise™ Stem:

- 11x19,5mm with 11,4mm circlip
- 11x19,5mm with 110,6mm circlip

### Push fit stems:

- 10x22mm with 10,3mm circlip
- 10x22mm with 10,5mm circlip
- 11x19,5mm with 11,4mm circlip
- 11x19,5mm with 11,8mm circlip
- 11x22mm with 11,4mm circlip
- 11x22mm with 11,6mm circlip
- 11x22mm with 11,8mm circlip

### Threaded stems:

- M8x15mm
- M8x20mm
- M8x25mm
- M10x15mm
- M10x20mm
- M10x25mm
- M10x30mm
- M10x40mm
- M12x20mm

### Square plates:

- 38x38mm
- 55x55mm
- 60x60mm